



300-CW Series

Cold Food Drop-In Well



- Coldwall drop-in refrigerated cold display pan.
- Meets NSF Std. #7 for cold holding at 41°F (5°C) or below.
- Exterior body is corrosion resistant steel.
- Interior fitted with drain at one end. Drain nipple with 3/4" thread supplied with gate valve.
- Insulated with CFC free, foamed in place polyurethane.
- Recessed, stainless steel ledge provided for supporting pans, adaptor bars included.
- Stainless steel top and covered corner interior.
- Dual air movement louver provided.
- Adjustable thermostat provides cold holding temperature flexibility.
- Condensing unit mounted on a swivel platform that allows for 90 degrees of rotation of intake/exhaust louver, giving the customer the option of mounting the louver on any of the counter four sides.

The 300-CW is a self-contained, wrapped coldwall drop-in refrigerated cold display pan with one piece stainless steel interior and top. 1" (25mm) drain with 3/4" thread, and gate valve provided. R290 refrigerant. Wrapped refrigeration construction, expansion valve, and adjustable thermostatic control. Entire system is mounted on corrosion resistant framework, suspended below unit body. Sliding shroud and dual air movement louver included to direct air flow.

The unit holds three (3) 6" (176mm) deep full-size pans or a combination of standard (gastronorm) pan sizes. The cold well includes four (4) 20" (508mm) pan divider bars.

Model 300-CW: refrigerated unit for cold display without ice, self-contained 1/4 hp compressor

Model 300-CW/R: refrigerated unit for cold display without ice, for use with a remote compressor





300-CW Series

Cold Food Drop-In Well

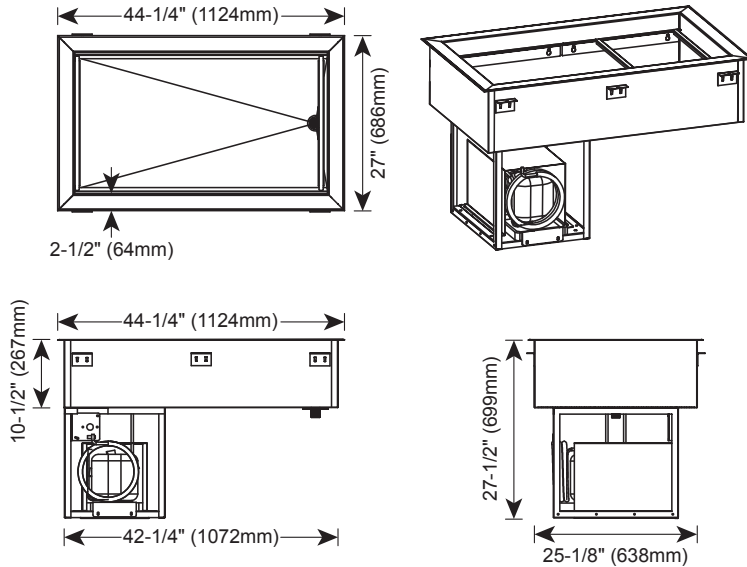

Accessories	
Pan Divider Bars	
12" (305mm) for Half-Size / Third-Size pans	1014395
Remote on/off switch	SW-35840
8' (2438mm) Extension,	
Cutout (H x W):	Contact Factory

300-CW Dimensions: H x W x D	
Exterior:	27-1/2" x 44-1/4" x 27" (699mm x 1124mm x 686mm)
Interior cold well:	6-1/4" x 39-1/4" x 22" (159mm x 997mm x 559mm)
Counter cutout (L x W):	42-3/4" x 25-1/2" (1085mm x 648mm)
Dual air movement louver cutout (H x W):	21" x 16" (533mm x 406mm)

Electrical					
V	Ph	Hz	A	kW	Plug
115	1	60	5.0	.6	 NEMA 5-15P 15A-125V plug 9' (229mm) long cord

Installation Requirements	
The countertop material must be water resistant.	
A distance of 3/4" (19mm) or more is required between the top rims of the wells to ensure easy cleaning.	
The cold well must be installed level.	
The cold well must not be installed in any area where the cold well may be directly affected by steam, grease, dripping water, high temperatures, or any other severely adverse conditions.	
The cold well must not be installed under a hood.	
Avoid installing the cold well under a 4-way ceiling diffuser.	
Outdoor use is not recommended.	
A water drain or a water catch basin is required for the cold well.	
LED lighting is recommended for overhead lighting.	

Product/Pan Capacity (Based on 6" deep pans)	
108 lb (48.9 kg)	
Max. volume: 66 qt. (62 L)	
Full-Size Pans*:	Three (3) 12" x 20" x 6" GN 1/1 (325mm x 530mm x 176mm)
Half-Size Pans*:	Six (6) 12" x 10" x 6" GN 1/2 (325mm x 265mm x 176mm)
Third-Size Pans*:	Nine (9) 12" x 6" x 6" GN 1/3 (325mm x 176mm x 176mm)

*will also accept 2-1/2" (65mm) and 4" (102mm) deep pans

Clearance Requirements	
4" (102mm) in front of dual air movement louver	

Weight	300-CW	300-CW/R
Net Weight:	210 lb (95 kg) est.	Contact Factory
Ship Weight:	260 lb (118 kg)	Contact Factory
Crate Dimensions: (L x W x H)	49-1/2" x 32" x 36-1/2" (1257 x 813 x 927mm)	Contact Factory

Remote BTU Requirements	
Low temp compressor: -10°F suction line	
**BTU load: 700	
**Does not include line run for remote compressor	



W164 N9221 Water Street • P.O. Box 450 • Menomonee Falls, Wisconsin 53052-0450 • U.S.A.
Phone: 262.251.3800 800.558.8744 U.S.A./Canada Fax: 262.251.7067 800.329.8744 U.S.A. only
www.alto-shaam.com